

IN8044

Rear Door Ladder - Universal

SUPPLIED COMPONENTS		#	DESCRIPTION	QTY
		1	REAR DOOR LADDER	1
		2	SPACER BRACKET [LEFT HAND]	2
		3	SPACER BRACKET [RIGHT HAND]	2
		4	OUTER FIXING BRACKET	2
		5	INTERNAL FIXING PLATE	2
SUPPLIED FIXING KIT		#	DESCRIPTION	QTY
		1	M6x16 HEX BOLT	8
		2	M8x30 HEX BOLT	4
		3	M8 SERRATED FLANGE NUT	8
		4	M6 SERRATED FLANGE NUT	8
		5	M6 WASHER	16
		6	M8 WASHER	16
		7	ANTI CRUSH TUBE	4
		8	M8x90 HEX BOLT	4
		9	M8x20 HEX BOLT	4
		10	H330 RUBBER PAD	2

TOOLS REQUIRED: 10mm & 13mm SPANNER / RATCHET, 8.5mm DRILL BIT, DRILL

This FITTING INSTRUCTION is the property of VAN GUARD ACCESSORIES LTD. and must not be used for manufacturing purposes, copied nor communicated in any way to third parties without written permission from VAN GUARD ACCESSORIES LTD.

IN8044_A

Van Guard Accessories Ltd
 Fair Oak Close, Exeter Airport Business Park,
 Exeter, Devon, EX5 2UL
www.van-guard.co.uk

IMPORTANT NOTES

1. Ensure ladder is suitable for your vehicle.
2. Do not install the ladder in front of or below rear bumper.
3. Always wear safety glasses when drilling.
4. Ladder only to be used when rear doors are fully closed.
5. Ladder has a maximum weight limit of 100kg.
6. Read through the instructions before fitting the ladder.
7. When fitting Ford Transit (2000-2013) rear door ladders a brace plate is required to be fitted, refer to the VG116T instructions.

Whilst every effort has been made to ensure all of our products can be safely fitted, we cannot accept any liability for damage caused either by the fitting or improper use of our products. Please check that no pipes, tanks, wiring etc... will obstruct any drilling operation and the weight restriction limit is adhered to.

- 1** Please read the important notes above before fitting this product.

Stick a rubber pad to the outer fixing brackets.

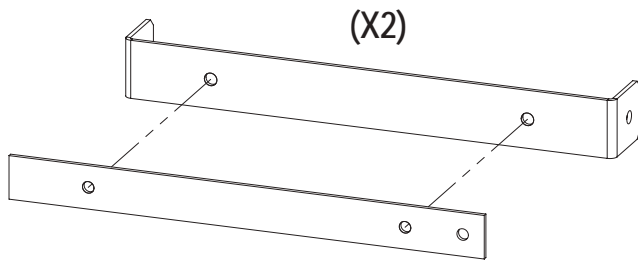

- 2** Loosely secure the spacer brackets to the outer fixing brackets using M8x20 hex bolts, M8 washers & M8 serrated nuts.

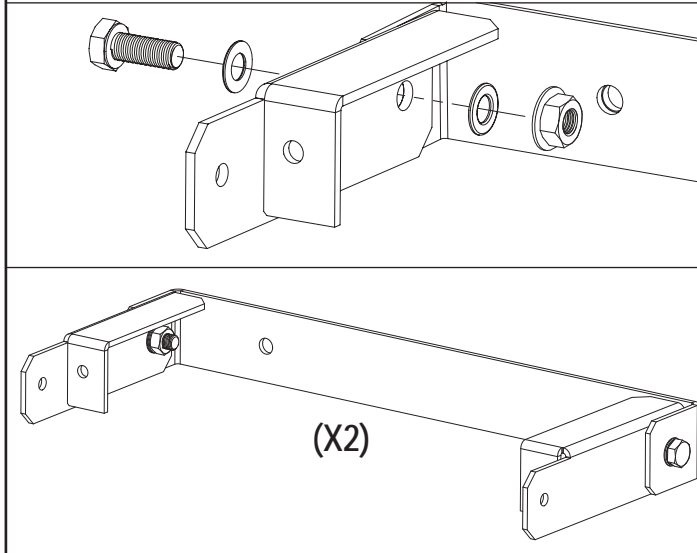

- 3** Secure the assemblies from step 2 to the ladder to suit the position of your vehicle using M6x16 hex bolts (x8), M6 washers (x16) & M6 serrated nuts (x8).

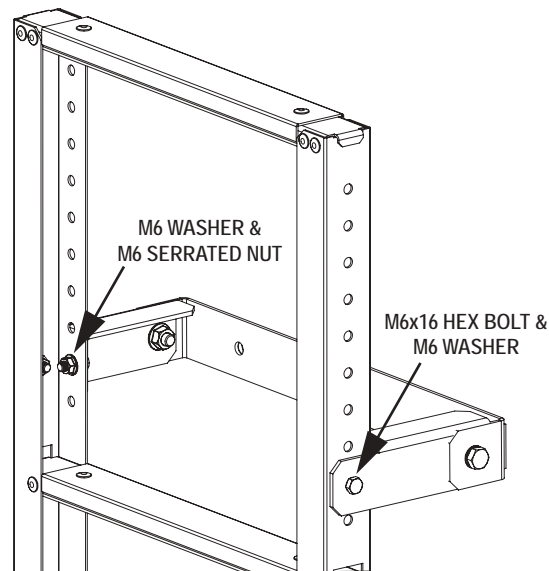

- 4** Do not install the ladder in front of or below the rear bumper.

Using the internal fixing plate as a template and vertically centered on the rear door, drill four $\varnothing 8.5\text{mm}$ fixing holes through the rear door to suit the assembled ladder bracket position. Ensure that the positions are correct before drilling.

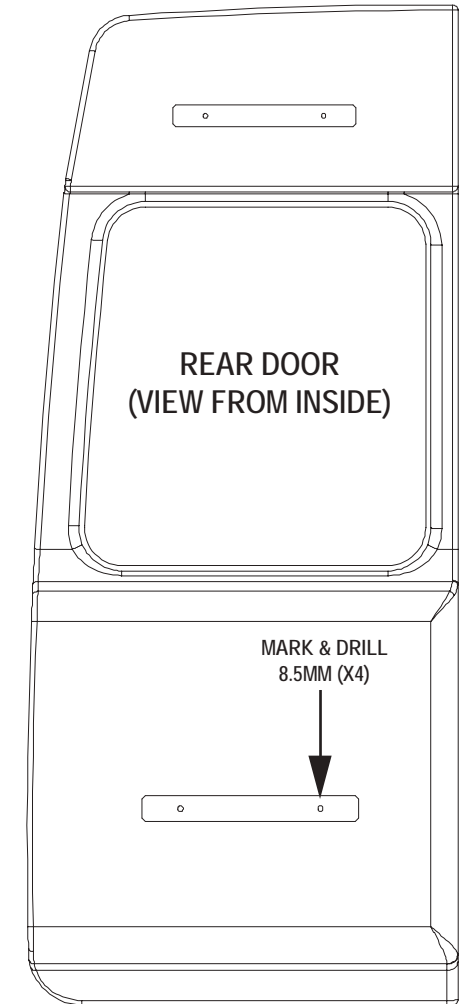

5.1 The following step is for fitting to a single skinned rear door. If your rear door is double skinned refer to step 5.2

Secure the assembled ladder to the rear door using M8x30 hex bolts (x4), M8 washers (x8), internal fixing plates (x2) & M8 serrated nuts (x4)

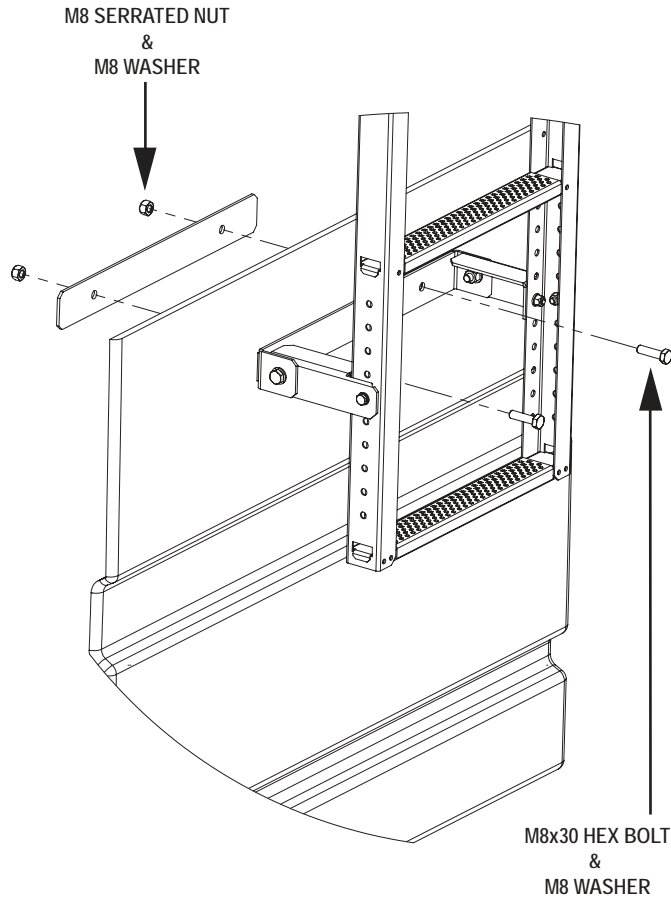

5.2 The following step is for fitting to a double skinned rear door. If your rear door is single skinned refer to step 5.1

If the rear door is double skinned, drill $\varnothing 15.5\text{mm}$ holes on the **outside** of the door to replace the $\varnothing 8.5\text{mm}$ holes that were drilled in step 4.

Trim the anti crush tube to fit inside the rear door. Secure the assembled ladder to the rear door using M8x90 hex bolts (x4), M8 washers (x8), internal fixing plates (x2) & M8 serrated nuts (x4)

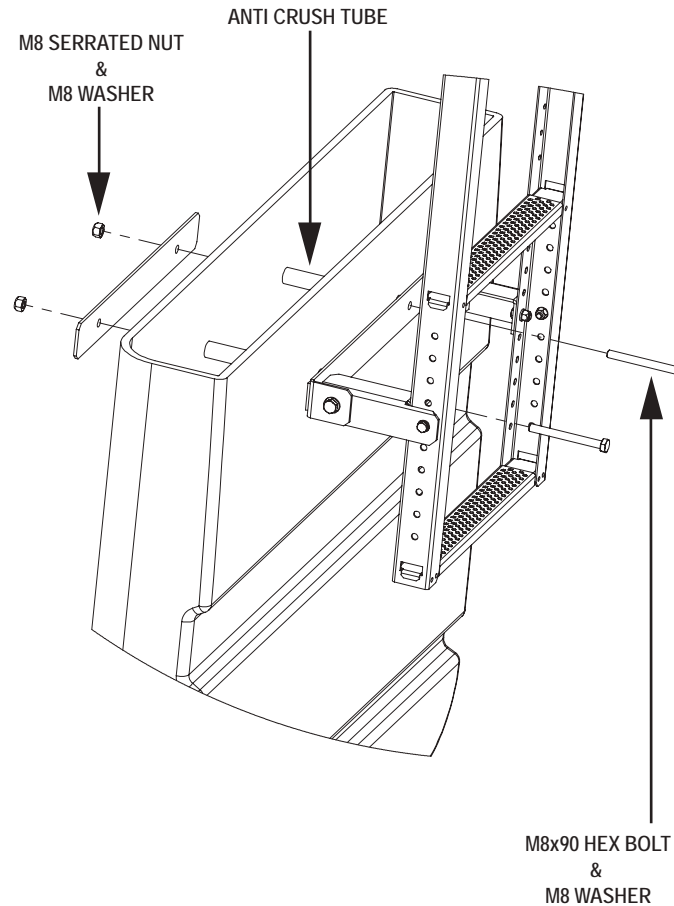

6 Once in position tighten all fixings.



NOTES:
Periodically check all fixings.
Retain these instructions for future reference.

VAN
GUARD